

Diaphragm seal with threaded connection

Welded design

Model 990.34

WIKA data sheet DS 99.04



for further approvals
see page 6

Applications

- Aggressive, hot, corrosive, environmentally hazardous or toxic media
- Oil and gas industry, chemical and petrochemical industries
- Water treatment
- Versatile in application

Special features

- Process connection with thread
- Version with internal diaphragm, diaphragm seal parts fully welded
- Large selection of process connections and materials
- Flushing connections optionally available
- High pressures up to 1,000 bar [14,500 psi] can be achieved

Description

Diaphragm seals are used for the protection of pressure measuring instruments in applications with difficult media. In diaphragm seal systems, the diaphragm of the diaphragm seal effects the separation of the instrument and the medium. The pressure is transmitted to the measuring instrument via the pressure transmission medium which is inside the diaphragm seal system.

For the implementation of demanding customer applications, there is a wide variety of designs, materials and pressure transmission mediums available.

For further technical information on diaphragm seals and diaphragm seal systems see IN 00.06 "Application, operating principle, designs".



**Diaphragm seal with threaded connection,
model 990.34**

The diaphragm seal with threaded connection, model 990.34, is suitable for very versatile application areas. Depending on the material, the welded design can also be used for particularly high nominal pressures up to 1,000 bar [14,500 psi]. Another benefit of the welded joint is that no additional sealing between the upper and lower body of the diaphragm seal is needed.

Mounting of the diaphragm seal to the measuring instrument may be made via a direct connection, for high temperatures via a cooling element or via a flexible capillary.

For the material selection, WIKA offers a variety of solutions, in which the diaphragm seal can be made of different materials.

Specifications

Model 990.34	
Pressure range (see pressure-temperature diagrams from page 4)	0 ... 0.6 bar [0 ... 8.7 psi] to 0 ... 1,000 bar [0 ... 14,500 psi] other units (e.g. psi, kPa) as well as all equivalent vacuum or combined pressure and vacuum ranges are available.
Level of cleanliness of wetted parts	<ul style="list-style-type: none"> ■ Oil and grease free per ASTM G93-03 level F WIKA standard (< 1,000 mg/m²) ■ Oil and grease free per ASTM G93-03 level D and ISO 15001 (< 220 mg/m²)
Origin of wetted parts	<ul style="list-style-type: none"> ■ International ■ EU, CH, USA
Connection to the measuring instrument	<ul style="list-style-type: none"> ■ Axial gauge adapter ■ Axial gauge adapter with female thread G ½, G ¼, ½ NPT or ¼ NPT ■ Male thread 9/16-18 UNF
Type of mounting	<ul style="list-style-type: none"> ■ Direct mounting ■ Capillary ■ Cooling element
Flushing connection	<ul style="list-style-type: none"> ■ Without ■ Single flushing connection (G ¼, G ⅛, ¼ NPT, ⅛ NPT) ■ Dual flushing connection (G ¼, G ⅛, ¼ NPT, ⅛ NPT) ■ Plug screws
Design per NACE	<ul style="list-style-type: none"> ■ Without ■ MR 0175 ■ MR 0103
Vacuum service (see IN 00.25)	<ul style="list-style-type: none"> ■ Basic service ■ Premium service ■ Advanced service
Instrument mounting bracket (only for versions with capillary)	<ul style="list-style-type: none"> ■ Without ■ Form H per DIN 16281, 100 mm, aluminium, black ■ Form H per DIN 16281, 100 mm, stainless steel ■ Bracket for pipe mounting, for pipe outer Ø 20 ... 80 mm, steel (see data sheet AC 09.07)

Example: Diaphragm seal model 990.34 with mounted pressure sensor

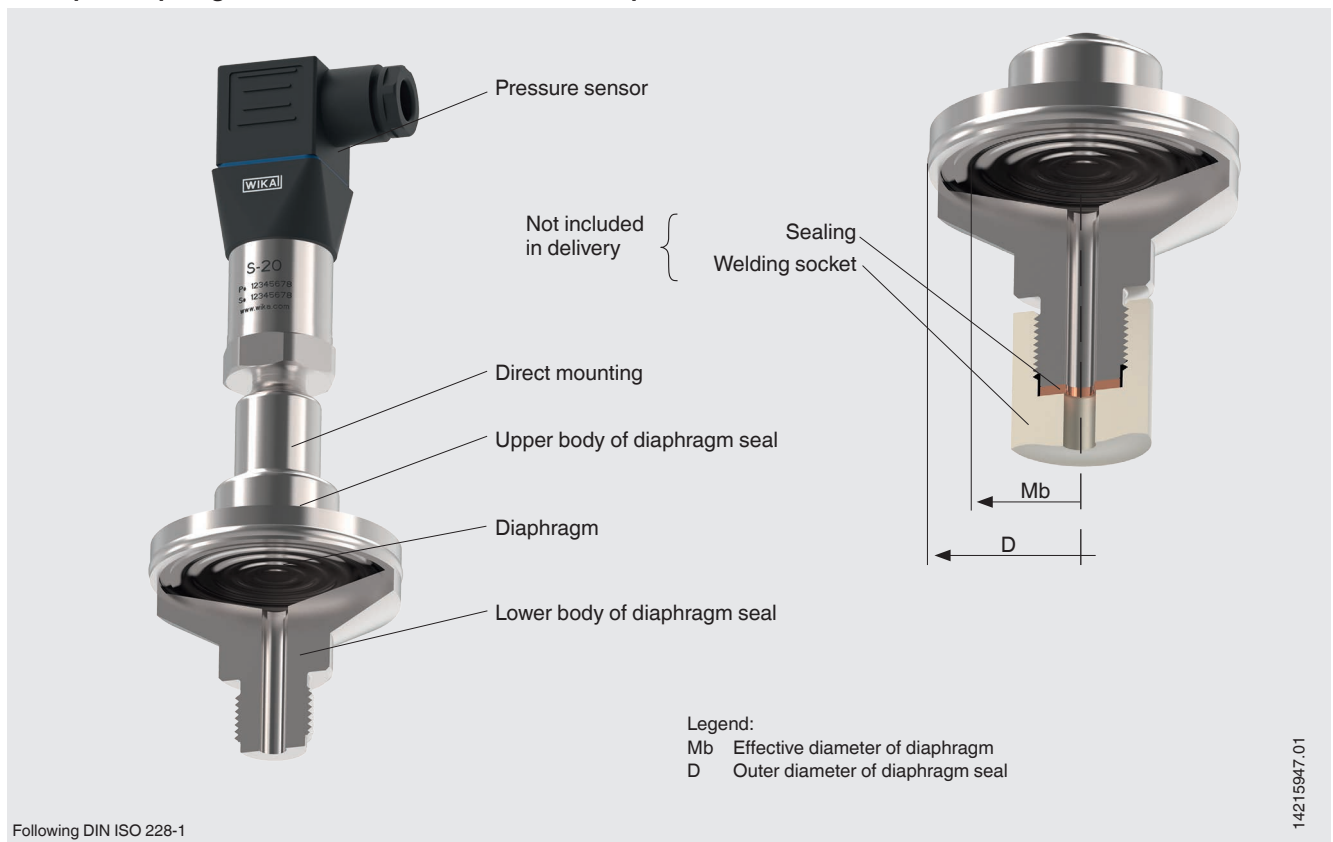

Process connection

Standard	Male thread	Female thread
Following DIN ISO 228-1	<ul style="list-style-type: none"> ■ G ½ A ■ G ¼ A ■ G ⅜ A ■ G ¾ A ■ G 1 A ■ G 1 ½ A 	<ul style="list-style-type: none"> ■ G ½ ■ G ¼ ■ G ⅜ ■ G ¾ ■ G 1
Following ANSI B 1.20.1	<ul style="list-style-type: none"> ■ ½ NPT ■ ¼ NPT ■ ⅜ NPT ■ ¾ NPT ■ 1 NPT ■ 1 ½ NPT 	<ul style="list-style-type: none"> ■ ½ NPT ■ ¼ NPT ■ ⅜ NPT ■ ¾ NPT ■ 1 NPT
Following ANSI B 1.1	<ul style="list-style-type: none"> ■ 9/16-18 UNF ■ 3/4-16 UNF 	<ul style="list-style-type: none"> ■ 9/16-18 UNF ■ 3/4-16 UNF
Following DIN 13-1	<ul style="list-style-type: none"> ■ M20 x 1.5 	<ul style="list-style-type: none"> ■ M20 x 1.5
Following ISO 7-1	<ul style="list-style-type: none"> ■ R ½ ■ R ¼ ■ R ⅜ ■ R ¾ 	

Other process connections on request

Permissible nominal pressure (PN)

The permissible nominal pressure (PN) of the diaphragm seal system results from the selected material and depends on the effective diaphragm diameter of the diaphragm seal (see table below). In addition, the permissible pressure/temperature rating must be taken into account. For the relevant pressure-temperature diagrams, see page 4 and 5.

The maximum permissible process temperature of the diaphragm seal system is also limited by the joining method, by the system fill fluid and by the measuring instrument.

Material of upper body of diaphragm seal and wetted parts ¹⁾	Nominal pressure (PN) in bar for effective diameter of diaphragm Mb in mm			
	PN 160	PN 400	PN 600	PN 1000
Stainless steel 1.4404 (316L)	Mb 52	Mb 40, Mb 29	Mb 22	
Stainless steel 1.4571 (316Ti)	Mb 52	Mb 40, Mb 29		
Stainless steel 1.4539 (904L)	Mb 52			
Stainless steel 1.4541 (321)	Mb 52			
Duplex 2205 (1.4462)	Mb 52	Mb 40	Mb 29	
Superduplex 2507 (1.4410)	Mb 52			
Hastelloy C22 (2.4602)	Mb 52		Mb 29	
Hastelloy C276 (2.4819)	Mb 52	Mb 40, Mb 29		Mb 22
Inconel 625 (2.4856)	Mb 52	Mb 40	Mb 29	Mb 22
Incoloy 825 (2.4558)	Mb 52	Mb 40, Mb 29	Mb 22	
Monel 400 (2.4360) ²⁾	Mb 40, Mb 29			
Titanium grade 2 (3.7035)	Mb 52	Mb 29		

1) Wetted parts: Lower body of diaphragm seal and diaphragms

2) With Mb 52, max. PN 100 possible

These versions require an application test

The effective diameter of diaphragm depends on the selected diaphragm seal system (e.g. mounting type, measuring instrument, scale range)

Pressure-temperature diagram
Effective diameter of diaphragm Mb 52 mm

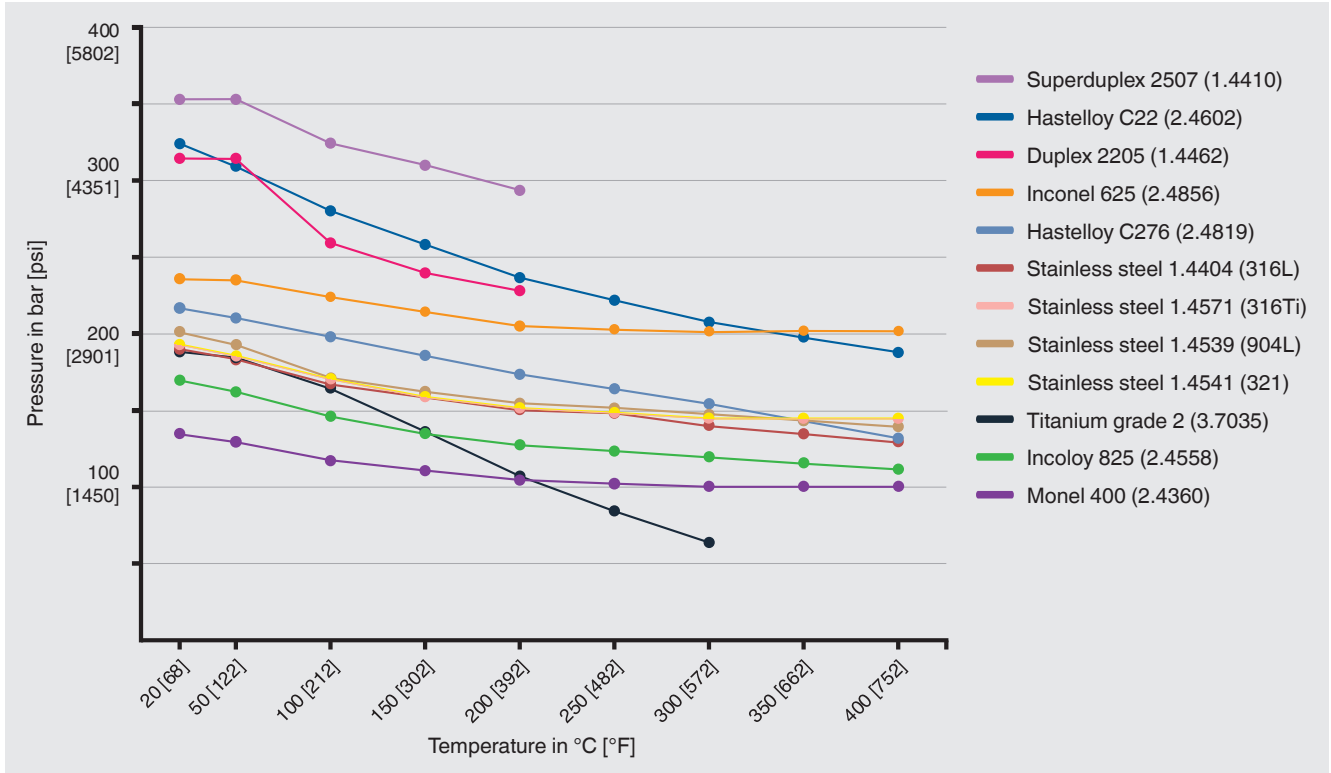

Pressure-temperature diagram
Effective diameter of diaphragm Mb 40 mm

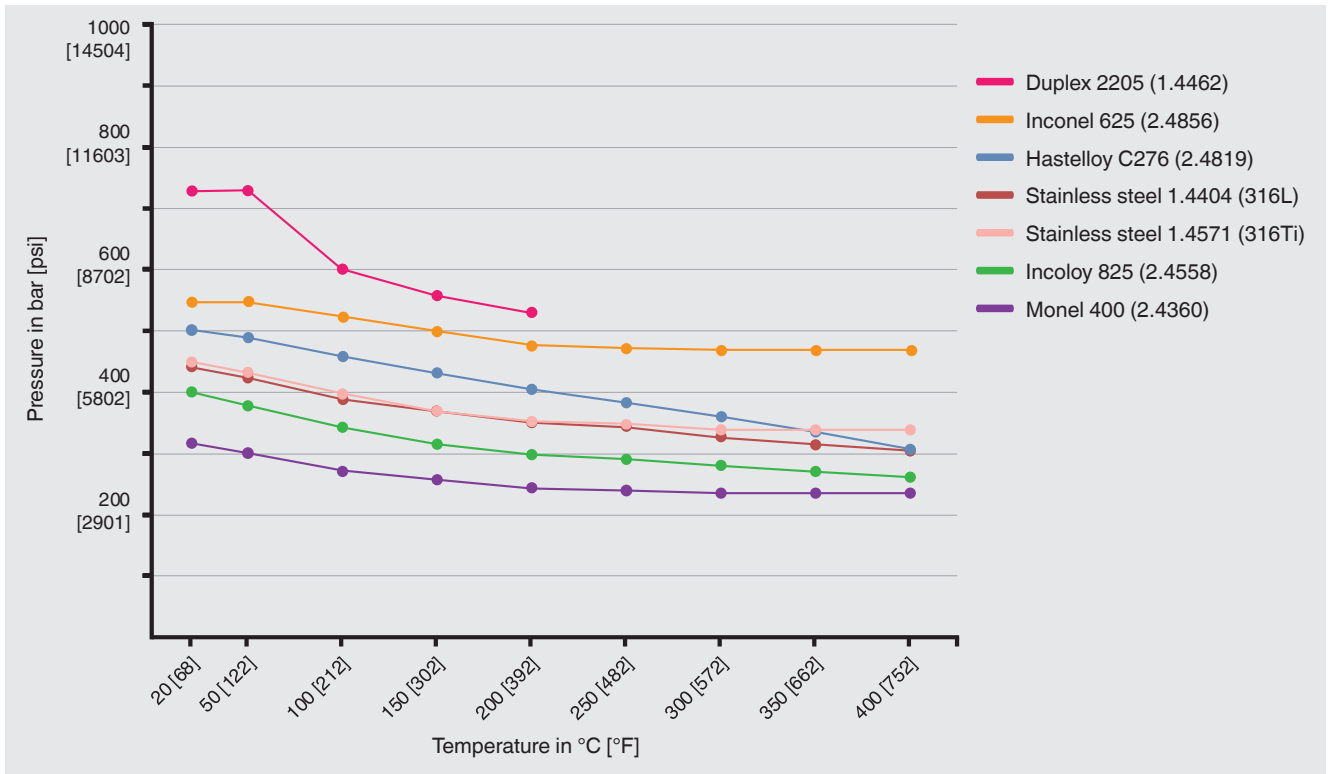

Pressure-temperature diagram
Effective diameter of diaphragm Mb 29 mm

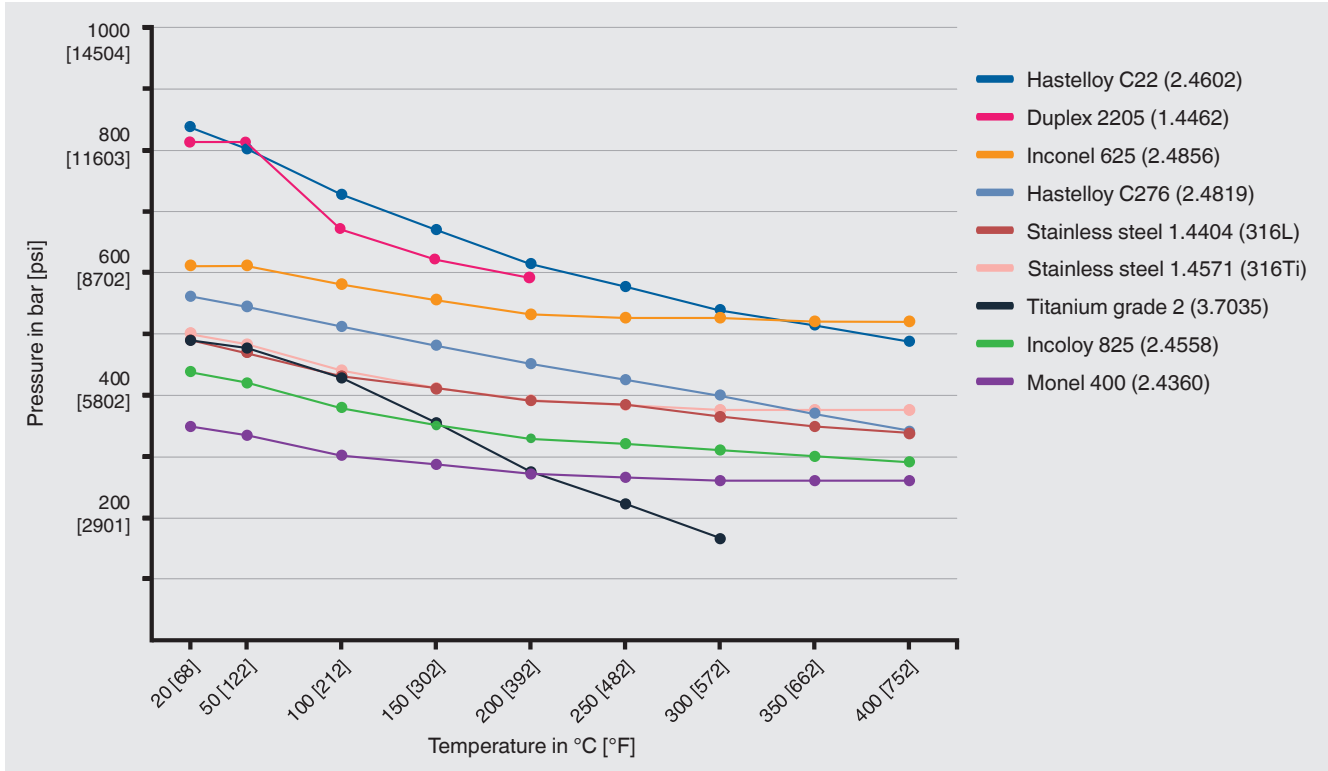

Pressure-temperature diagram
Effective diameter of diaphragm Mb 22 mm

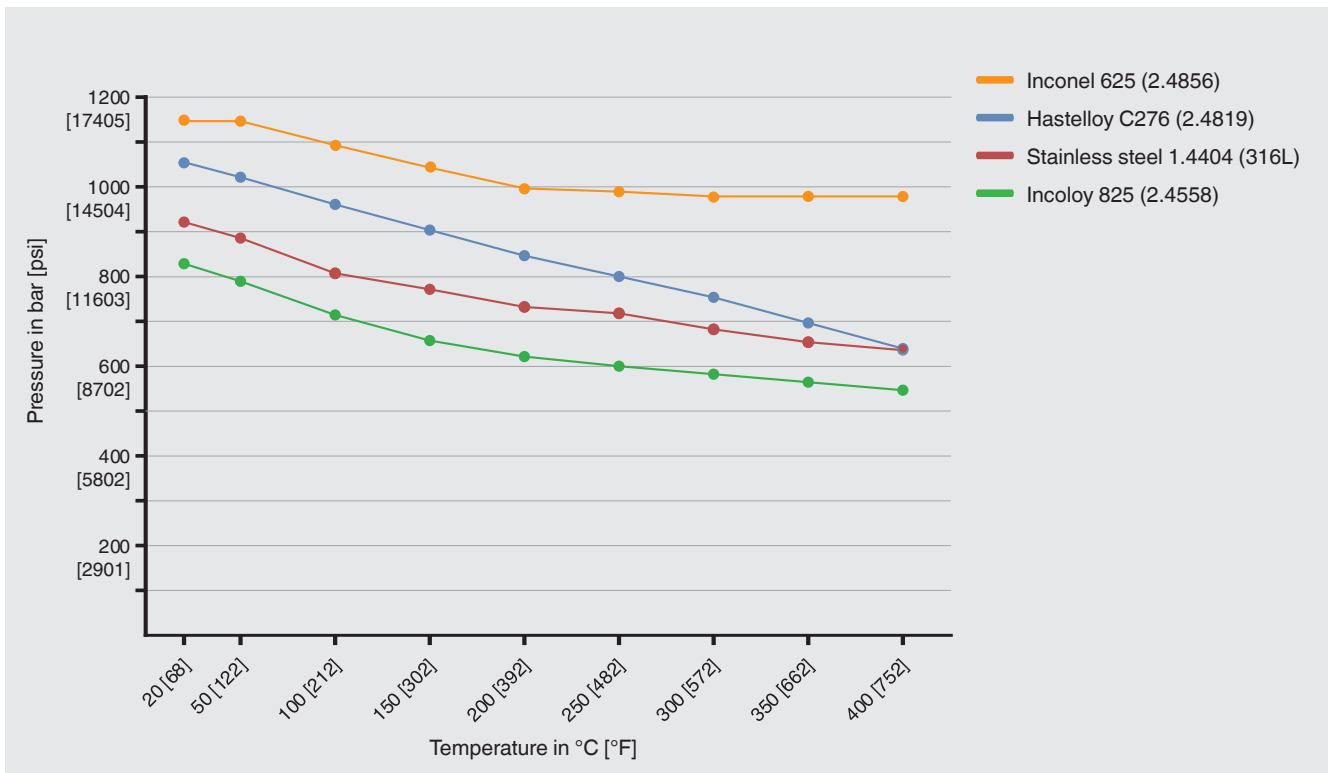

Approvals

Logo	Description	Country
	EAC (option) Pressure equipment directive	Eurasian Economic Community
-	MTSCHS (option) Permission for commissioning	Kazakhstan
-	CRN Safety (e.g. electr. safety, overpressure, ...)	Canada

Certificates (option)

- 2.2 test report per EN 10204 (e.g. state-of-the-art manufacturing, material proof, indication accuracy for diaphragm seal systems)
- 3.1 inspection certificate per EN 10204 (e.g. material proof for wetted metal parts, indication accuracy for diaphragm seal systems)

Approvals and certificates, see website

Diaphragm seal, model 990.34
Effective diameter of diaphragm Mb 52 mm

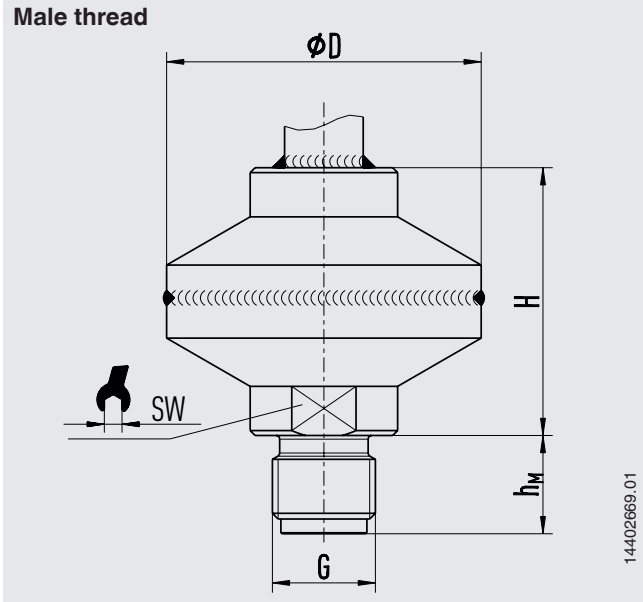

G	Dimensions in mm [in]			
	D	H ¹⁾	h _M	SW
G ¼ A	64 [2.52]	54.5 ... 75.5 [2.15 ... 2.93]	13 [0.51]	27 [1.06]
G ⅜ A	64 [2.52]	54.5 ... 75.5 [2.15 ... 2.93]	16 [0.63]	27 [1.06]
G ½ A	64 [2.52]	54.5 ... 75.5 [2.15 ... 2.93]	20 [0.79]	27 [1.06]
G ¾ A	64 [2.52]	54.5 ... 75.5 [2.15 ... 2.93]	20 [0.79]	41 [1.61]
G 1 A	64 [2.52]	54.5 ... 75.5 [2.15 ... 2.93]	28 [1.10]	41 [1.61]
¼ NPT	64 [2.52]	54.5 ... 75.5 [2.15 ... 2.93]	13 [0.51]	27 [1.06]
½ NPT	64 [2.52]	54.5 ... 75.5 [2.15 ... 2.93]	19 [0.75]	27 [1.06]
¾ NPT	64 [2.52]	54.5 ... 75.5 [2.15 ... 2.93]	20 [0.79]	32 [1.26]
1 NPT	64 [2.52]	54.5 ... 75.5 [2.15 ... 2.93]	25 [0.98]	41 [1.61]
M20 x 1.5	64 [2.52]	54.5 ... 75.5 [2.15 ... 2.93]	20 [0.79]	27 [1.06]
R ¼	64 [2.52]	54.5 ... 75.5 [2.15 ... 2.93]	15 [0.59]	27 [1.06]
R ½	64 [2.52]	54.5 ... 75.5 [2.15 ... 2.93]	19 [0.75]	27 [1.06]
R 1	64 [2.52]	54.5 ... 75.5 [2.15 ... 2.93]	19 [0.75]	41 [1.61]
1 ⅛-12 UNF	64 [2.52]	54.5 ... 75.5 [2.15 ... 2.93]	19 [0.75]	41 [1.61]

1) The dimension depends on the connection to the measuring instrument

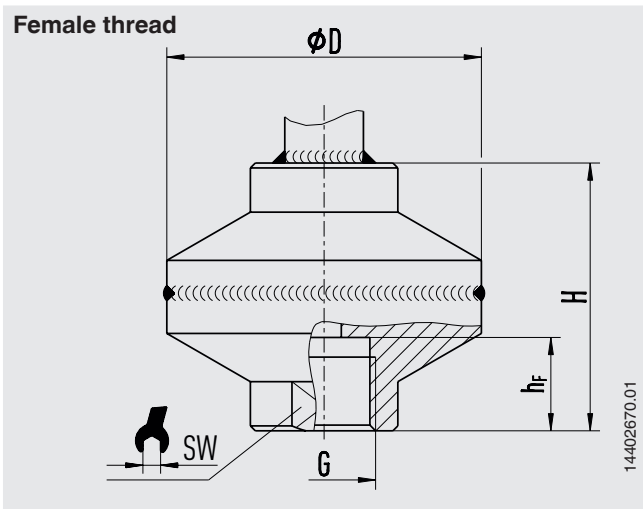

G	Dimensions in mm [in]			
	D	H ¹⁾	h _F	SW
G ¼	64 [2.52]	54.5 ... 75.5 [2.15 ... 2.93]	13 [0.51]	27 [1.06]
G ⅜	64 [2.52]	54.5 ... 75.5 [2.15 ... 2.93]	16 [0.63]	27 [1.06]
G ½	64 [2.52]	54.5 ... 75.5 [2.15 ... 2.93]	19 [0.75]	27 [1.06]
G ¾	64 [2.52]	62.5 ... 83.5 [2.46 ... 3.29]	24 [0.94]	32 [1.26]
¼ NPT	64 [2.52]	54.5 ... 75.5 [2.15 ... 2.93]	13 [0.51]	27 [1.06]
½ NPT	64 [2.52]	54.5 ... 75.5 [2.15 ... 2.93]	19 [0.75]	27 [1.06]
¾ NPT	64 [2.52]	54.5 ... 75.5 [2.15 ... 2.93]	22 [0.87]	32 [1.26]
1 NPT	64 [2.52]	68.5 ... 89.5 [2.70 ... 3.52]	26 [1.02]	46 [1.81]

1) The dimension depends on the connection to the measuring instrument

Diaphragm seal, model 990.34
Effective diameter of diaphragm Mb 40 mm

Male thread

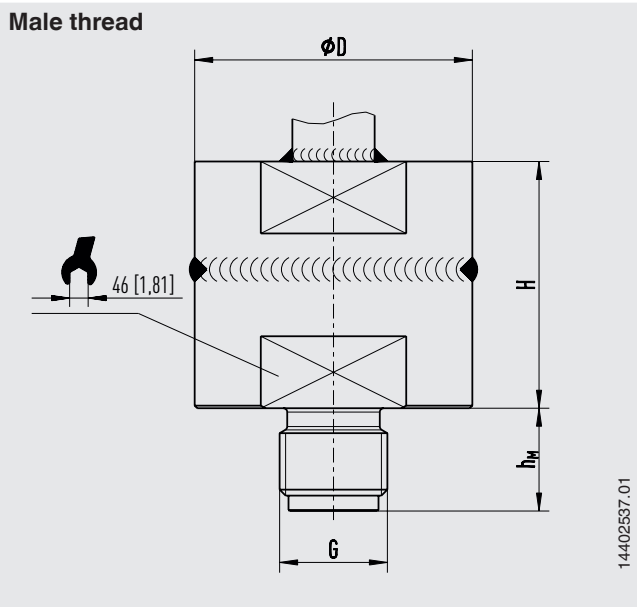

G	Dimensions in mm [in]		
	D	H ¹⁾	h _M
G ¼ A	54 [2.13]	48 ... 66 [1.89 ... 2.60]	13 [0.51]
G ⅜ A	54 [2.13]	48 ... 66 [1.89 ... 2.60]	16 [0.63]
G ½ A	54 [2.13]	48 ... 66 [1.89 ... 2.60]	20 [0.79]
G ¾ A	54 [2.13]	48 ... 66 [1.89 ... 2.60]	20 [0.79]
G 1 A	54 [2.13]	48 ... 66 [1.89 ... 2.60]	28 [1.10]
¼ NPT	54 [2.13]	48 ... 66 [1.89 ... 2.60]	13 [0.51]
½ NPT	54 [2.13]	48 ... 66 [1.89 ... 2.60]	19 [0.75]
¾ NPT	54 [2.13]	48 ... 66 [1.89 ... 2.60]	20 [0.79]
1 NPT	54 [2.13]	48 ... 66 [1.89 ... 2.60]	25 [0.98]
M20 x 1.5	54 [2.13]	48 ... 66 [1.89 ... 2.60]	20 [0.79]
R ¼	54 [2.13]	48 ... 66 [1.89 ... 2.60]	15 [0.59]
R ½	54 [2.13]	48 ... 66 [1.89 ... 2.60]	19 [0.75]

1) The dimension depends on the connection to the measuring instrument

Female thread

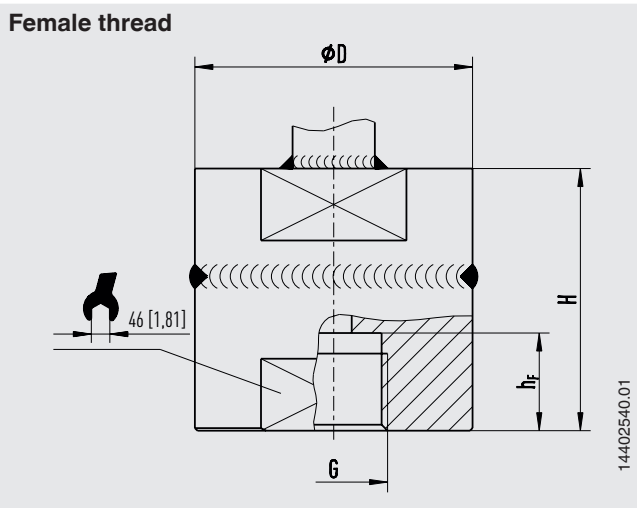

G	Dimensions in mm [in]		
	D	H ¹⁾	h _F
G ¼	54 [2.13]	51 ... 69 [2.01 ... 2.72]	13 [0.51]
G ½	54 [2.13]	51 ... 69 [2.01 ... 2.72]	19 [0.75]
¼ NPT	54 [2.13]	51 ... 69 [2.01 ... 2.72]	13 [0.51]
½ NPT	54 [2.13]	51 ... 69 [2.01 ... 2.72]	19 [0.75]
9/16-18 UNF	54 [2.13]	53 ... 71 [2.09 ... 2.76]	11.2 [0.44]

1) The dimension depends on the connection to the measuring instrument

Diaphragm seal, model 990.34
Effective diameter of diaphragm Mb 29 mm

Male thread

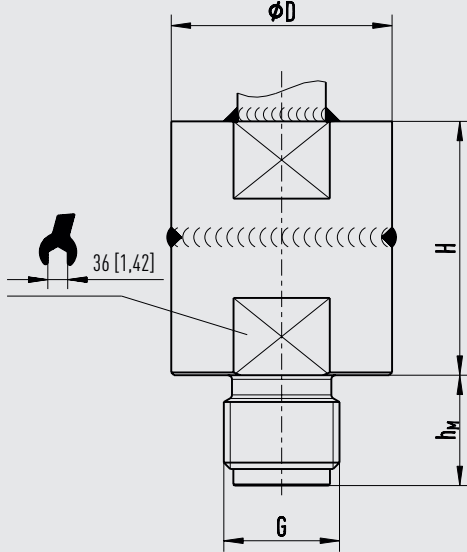

14402320.01

G	Dimensions in mm [in]		
	D	H ¹⁾	h _M
G ¼ A	40 [1.57]	46 ... 65 [1.81 ... 2.56]	13 [0.51]
G ½ A	40 [1.57]	46 ... 65 [1.81 ... 2.56]	20 [0.79]
G 1 A	40 [1.57]	46 ... 65 [1.81 ... 2.56]	28 [1.10]
¼ NPT	40 [1.57]	46 ... 65 [1.81 ... 2.56]	13 [0.51]
½ NPT	40 [1.57]	46 ... 65 [1.81 ... 2.56]	19 [0.75]
1 NPT	40 [1.57]	46 ... 65 [1.81 ... 2.56]	25 [0.98]
M20 x 1.5	40 [1.57]	46 ... 65 [1.81 ... 2.56]	20 [0.79]
R ¼	40 [1.57]	46 ... 65 [1.81 ... 2.56]	15 [0.59]
R ½	40 [1.57]	46 ... 65 [1.81 ... 2.56]	19 [0.75]

1) The dimension depends on the connection to the measuring instrument

Female thread

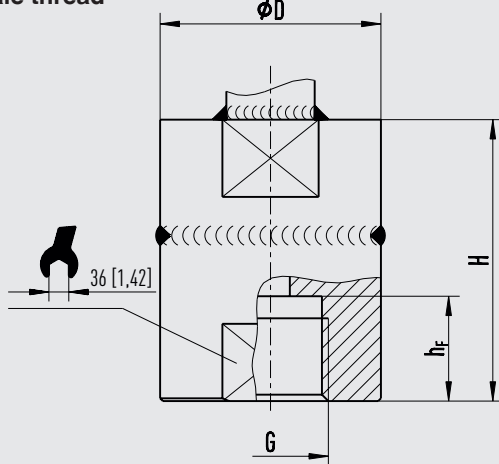

14402322.01

G	Dimensions in mm [in]		
	D	H ¹⁾	h _F
G ¼	40 [1.57]	46 ... 65 [1.81 ... 2.56]	13 [0.51]
G ½	40 [1.57]	51 ... 70 [2.01 ... 2.76]	19 [0.75]
¼ NPT	40 [1.57]	46 ... 65 [1.81 ... 2.56]	13 [0.51]
½ NPT	40 [1.57]	46 ... 65 [1.81 ... 2.56]	19 [0.75]
M16 x 1.5	40 [1.57]	51 ... 70 [2.01 ... 2.76]	12 [0.47]
3/4-16 UNF	40 [1.57]	51 ... 70 [2.01 ... 2.76]	15.7 [0.62]

1) The dimension depends on the connection to the measuring instrument

Diaphragm seal, model 990.34
Effective diameter of diaphragm Mb 22 mm

Male thread

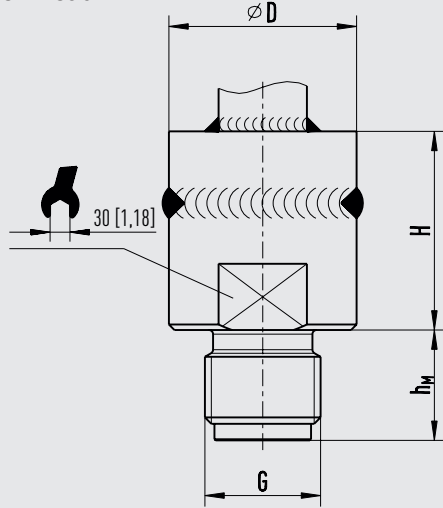

14402150.01

G	Dimensions in mm [in]		
	D	H ¹⁾	h _M
G ¼ A	34 [1.34]	36 ... 64 [1.42 ... 2.52]	13 [0.51]
G ½ A	34 [1.34]	36 ... 64 [1.42 ... 2.52]	20 [0.79]
G ¾ A	34 [1.34]	36 ... 64 [1.42 ... 2.52]	20 [0.79]
¼ NPT	34 [1.34]	36 ... 64 [1.42 ... 2.52]	13 [0.51]
½ NPT	34 [1.34]	36 ... 64 [1.42 ... 2.52]	19 [0.75]
M20 x 1.5	34 [1.34]	36 ... 64 [1.42 ... 2.52]	20 [0.79]
9/16-18 UNF	34 [1.34]	²⁾	²⁾
3/4-16 UNF	34 [1.34]	²⁾	²⁾

1) The dimension depends on the connection to the measuring instrument

2) On request

Female thread

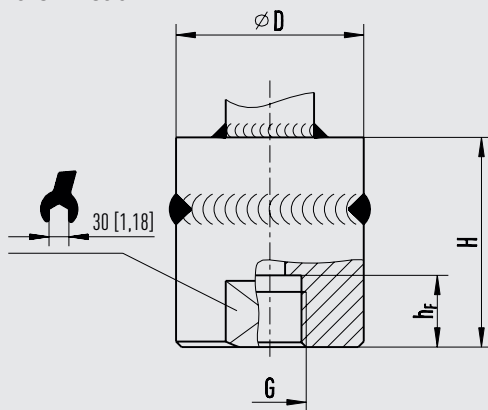

14402160.01

G	Dimensions in mm [in]		
	D	H ¹⁾	h _F
G ¼	34 [1.34]	²⁾	13 [0.51]
G ½	34 [1.34]	²⁾	19 [0.75]
¼ NPT	34 [1.34]	²⁾	13 [0.51]
½ NPT	34 [1.34]	41 ... 69 [1.61 ... 2.72]	19 [0.75]
M16 x 1.5	34 [1.34]	41 ... 69 [1.61 ... 2.72]	12 [0.47]
9/16-18 UNF	34 [1.34]	41 ... 69 [1.61 ... 2.72]	11.2 [0.44]
3/4-16 UNF	34 [1.34]	41 ... 69 [1.61 ... 2.72]	15.7 [0.62]

1) The dimension depends on the connection to the measuring instrument

2) On request

Ordering information

Diaphragm seal:

Diaphragm seal model / Process connection (process connection standard, thread, nominal pressure rating) / Material (upper body, diaphragm, lower body) / Flushing connection (plug screw) / Connection to the measuring instrument / Level of cleanliness of wetted parts / Origin of wetted parts / Certificates

Diaphragm seal system:

Diaphragm seal model / Process connection (process connection standard, thread, nominal pressure rating) / Material (upper body, diaphragm, lower body) / Flushing connection (plug screw) / Pressure measuring instrument model (per data sheet) / Mounting (direct mounting, cooling element, capillary) / Min. and max. process temperature / Min. and max. ambient temperature / Vacuum service / Pressure transmission medium / Certificates / Height difference / Level of cleanliness of wetted parts / Origin of wetted parts / Instrument mounting bracket

© 02/2000 WIKA Alexander Wiegand SE & Co. KG, all rights reserved.
The specifications given in this document represent the state of engineering at the time of publishing.
We reserve the right to make modifications to the specifications and materials.

